

# Box Sliding Arm



- Highly rigid, highly durable box structure.
- Sliding cylinder and bucket cylinder are housed inside the arm, to minimize arm extension and lessen worries about obstructions while working.

■ Applicable base machines

Sliding length	Appropriate model (m <sup>3</sup> )
0.8	0.14~0.22
1.1	0.28~0.40
1.5	0.28~0.40/0.45~0.50
2.0	0.45~0.50/0.8~1.0

\* Partial remodeling required for mounting, therefore contact MUROTO.

# Extention Arm



Mount on standard arm to expand range of work.

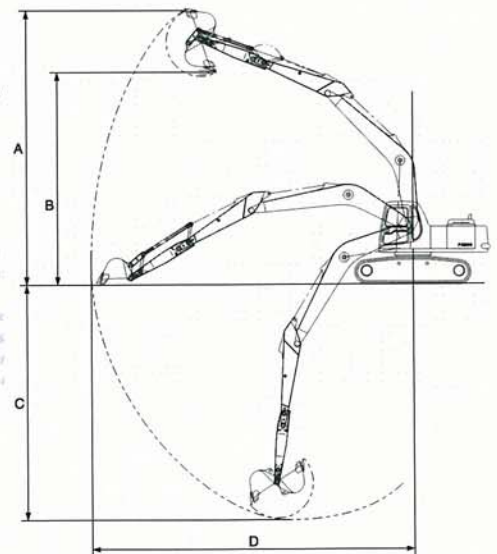

\* Ordinary extension arms destabilize excavator balance when mounted.

■ Specifications

Item	Appropriate model (m <sup>3</sup> )	0.14~0.22	0.28~0.4	0.50	0.8~1.0	0.28	0.28~0.4	0.45	0.8~1.0
A: Max. digging height (mm)		6830	7811	9490	9799	7951	7976	10373	11791
B: Max. dumping height (mm)		5075	5712	7047	7590	5808	5834	8023	8837
C: Max. digging depth (mm)		4770	5086	6376	8321	5127	5105	6940	8578
D: Max. digging radius (mm)		6385	7276	9700	11428	7110	7356	9631	11532
Operating bucket capacity		0.14	0.18	0.33	0.45	0.18	0.18	0.33	0.45
Arm length (mm)		800	1000	1500	2000	1000	1000	1500	2000

\* Some attachments are not compatible with certain excavators, therefore contact MUROTO.

\* For the sake of product improvement, specifications, performance and dimensions are subject to change without notice.